

L.B.G.

ASME FLASH TANK

RE SERIES

MODEL	DIMENSIONS										WEIGHT	
	A		B		C		D		E		lbs	kg
	in	mm	in	mm	in	mm	in	mm	in	mm		
RE6	6 5/8	168	51	1295	41	1041	8	203	2 1/2	64	78	36
RE8	8 5/8	219	52	1321	42	1067	8 1/2	216	4	102	117	53
RE12	12 3/4	324	55 1/2	1410	45 1/2	1156	12	305	5	127	182	83
RE16	16	406	63 1/2	1613	43 1/2	1359	13 1/2	343	6	152	249	114

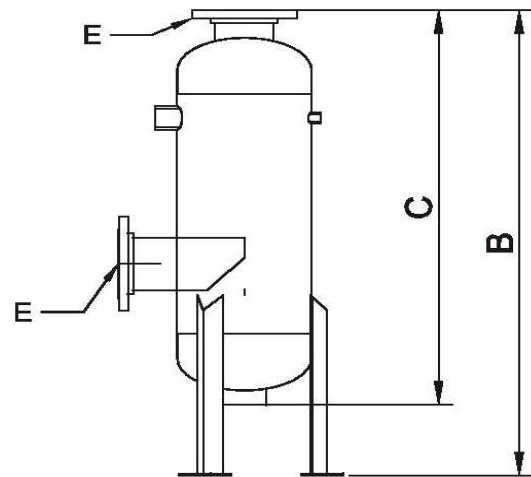
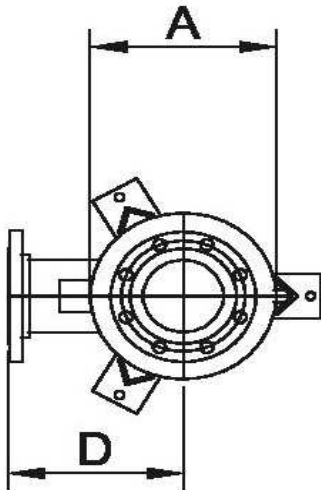

Spécifications

- CONSTRUCTED IN ACCORDANCE WITH THE ASME CODE, SEC VIII 2010 11a, DIV.1, PARAG. UW-12
- CONSTRUCTED IN ACCORDANCE WITH CSA B.51
- DESIGNED PRESSURE : 150 psi (1 034KPa), 550 °F (288 °C) AND MORE ON REQUEST
- CARBON STEEL CONSTRUCTION
- EXTERNAL FINISH : CLEANED WITH SOLVENT AND APPLICATION OF ONE COAT OF GREY PRIMER
- HYDROSTATIC TEST AND CRN INCLUDED